



KITS



PUMPS



METERS



METERED NOZZLES



NOZZLES



WASTE OIL EQUIPMENTS

FILTROLL

FEATURES

- DOUBLE-STAGE FILTRATION
- CLOGGING INDICATOR
- TRANSPORTABLE
- MANAGEABLE
- SPIRAL TUBES

The PIUSI FILTROLL is an innovative solution that allows the user to perform a circular filtering of any kind of tank. The built-in trolley allows the operator to easily handle this device in any condition.

PERFORMANCE

UP TO

25L/MIN

FLOW RATE

AC

VOLTAGE

POWER

DC VERSION

30MIN

ONLY FOR DIESEL

DUTY CYCLE



FILTROLL OIL/DIESEL



PACKAGING

CODE	WEIGHT		PACKAGING			
	KG	LBS	MM	INCH	PCS/PALLET	PCS/BOX
FO0506010	42	92,6	790X590X590	31,1X23,2X23,2		1



FILTRATION



FLUID MONITORING



TANK MONITORING



HOSE REELS



ACCESSORIES



MERCHANDISE

INDEX



AIR



ANTIFREEZE



AdBlue®



BIODIESEL



DIESEL



FOOD



GASOLINE



GREASE



KEROSENE



OIL



WATER



WINDSCREEN

CHART

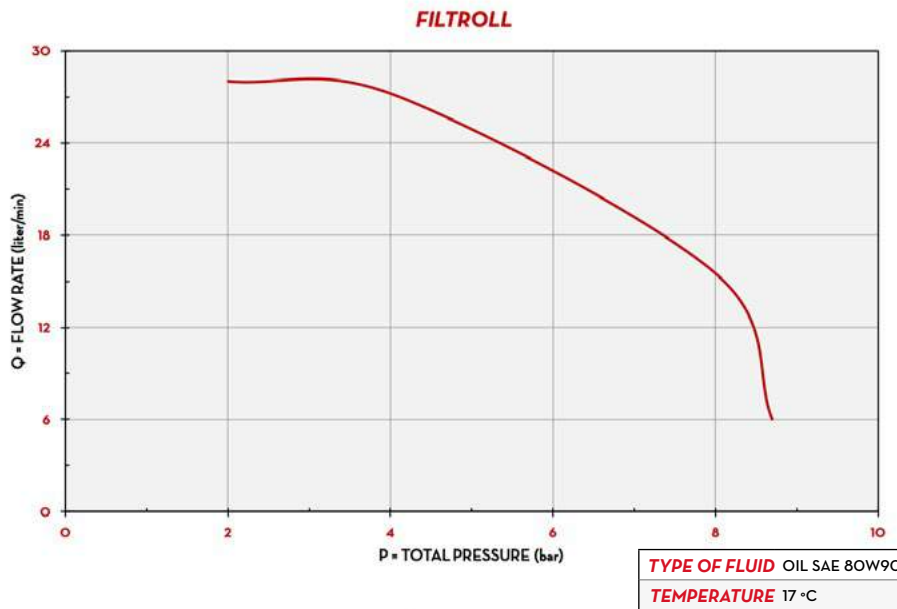

IN THE BOX

- FILTROLL UNIT
- SUCTION HOSE
- DELIVERY HOSE
- INSTRUCTION MANUAL

DETAILS



TWO STEP FILTRATION



STURDY STRUCTURE



LARGE DIAMETER WHEELS

DIMENSIONS

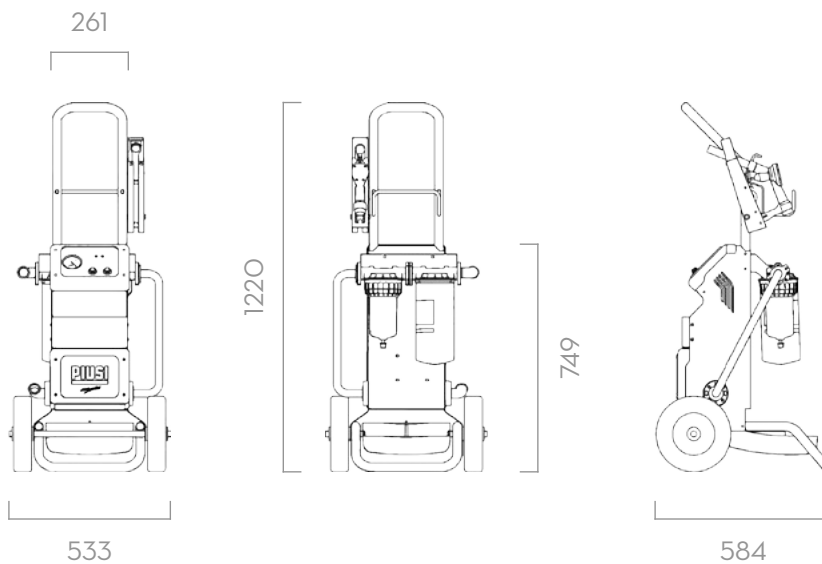

Dimensions expressed in millimeters

MATERIALS

- BODY: CAST IRON
- ROTOR: SINTERED STEEL
- VAINS: TECHNOPOLYMER
- SHAFT: STEEL
- FILTER: ABSORBENT FILTERING PAPER

TECHNICAL DATA

CODE	DESCRIPTION	FLUIDS TYPE	FLOW RATE		VOLTAGE			PUMP	HOSE LENGHT	
			L/MIN	GPM	AC V/HZ DC VOLT	POWER WATT	AMP. MAX.	TYPE	DELIVERY M/FT	SUCTION M/FT
FO0506010	FILTROLL OIL/DIESEL	D O	25	7	230/50	750	4,6	VISCOMAT 70	3 / 9,8	3 / 9,8

FILTROLL